

Low Noise, High IP3

Monolithic Amplifier

CMA-545G1+

50Ω 0.4 to 2.2 GHz

The Big Deal

- Ceramic, Hermetically Sealed, Nitrogen filled
- Low profile case, .045" high
- High Gain, 31.5 dB
- Low Noise Figure, 1.0 dB
- High IP3, 35-37 dBm
- Class 1B HBM ESD rating (500V)



CASE STYLE: DL1721

Product Overview

Mini-Circuits CMA-545G1+ is a E-PHEMT based Low Noise MMIC Amplifier operating from 0.4 to 2.2 GHz with a unique combination of low noise and high IP3 making this amplifier ideal for sensitive receiver applications. This design operates on a single +5V supply and is internally matched to 50 ohms. The MMIC amplifier is bonded to a multilayer integrated LTCC substrate and then hermetically sealed under a controlled nitrogen atmosphere with gold-plated covers and eutectic AuSn solder. These amplifiers have been tested to MIL requirements for gross leak, fine leak, thermal shock, vibration, acceleration, mechanical shock, and HTOL.

Key Features

Feature	Advantages
High Gain 25-32 dB	Incorporating multiple stages of amplification, the CMA-545G1+ provides high gain reducing cost and PCB board space.
Ultra Low Noise: 0.8 dB NF at 0.9 GHz	Excellent Noise Figure, measured in a 50 Ohm environment – without any external matching. When combined with high gain of this design, it suppresses second stage NF contribution.
High IP3: +36 dBm IP3 at 0.9 GHz	Combining Low Noise and High IP3 makes this MMIC amplifier ideal for Low Noise Receiver Front End (RFE) giving the user advantages at both ends of the dynamic range: sensitivity & two-tone IM dynamic range
Output Power: +22 dBm at 0.9 GHz	The CMA-545G1+ maintains consistent output power capability over the full operating temperature range making it ideal to be used in remote applications such as LNB's as the L Band driver stage
Internally Matched	No external matching elements required to achieve the advertised noise and output power over the full band
Ceramic Hermetic Package	Low Inductance, repeatable transitions, excellent reliability
Max Input Power +25 dBm	Ruggedized design operates up to input powers often seen at Receiver inputs.
High Reliability	Low, small signal operating current of 160 mA nominal maintains junction temperatures typically below 130°C at 85°C ground lead temperature



Low Noise, High IP3

Monolithic Amplifier

0.4-2.2 GHz

Product Features

- High Gain, 32 dB typ. at 0.9 GHz
- Ultra Low Noise Figure, 0.8 dB typ. at 0.9 GHz
- High IP3, 36 dBm typ. at 0.9 GHz
- High Pout, P1dB up to 22 dBm typ. at 0.9 GHz
- Single Positive Supply Voltage, 5V
- Class 1B HBM ESD rating (500V)
- Small size - 3mm x 3mm x 1.14mm
- Ceramic, hermetic, Nitrogen filled
- No external matching components required



CMA-545G1+

CASE STYLE: DL1721

+RoHS Compliant

The +Suffix identifies RoHS Compliance. See our web site for RoHS Compliance methodologies and qualifications

Typical Applications

- Cellular
- ISM
- GSM
- WCDMA
- LTE
- GPS

General Description

CMA-545G1+ is a high dynamic range, low noise, high IP3, high output power, monolithic amplifier. Manufactured using E-PHEMT* technology enables it to work with a single positive supply voltage. Unconditionally stable over the operating frequency. Terminal finish is Ni-Pd-Au and it has repeatable performance from lot to lot due to fully automated, tightly controlled semiconductor and assembly processes.

simplified schematic and pad description

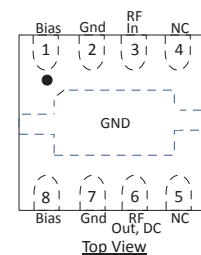
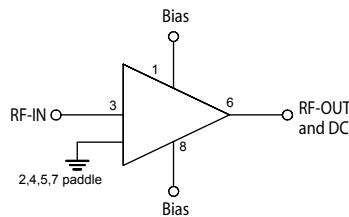

Function	Pad Number	Description (See Application Circuit, Fig. 2)
RF-IN	3	RF input pad (connected to RF-IN via C1)
RF-OUT & DC	6	RF output pad (connected to RF-OUT via blocking external cap C2, and Supply voltage Vs via RF Choke L2)
BIAS	1 & 8	Bias pad 1 connects to Vs via L1 & pad 8 connects to Vs
GND	bottom paddle 2&7	Connected to ground
NOT USED	4,5	No internal connection; recommend connecting to ground

*Enhancement mode Pseudomorphic High Electron Mobility Transistor.



Electrical Specifications⁽¹⁾ at 25°C, Vd=5V, Zo=50Ω, (refer to characterization circuit)

Parameter	Condition (MHz)	Min.	Typ.	Max.	Units
Frequency Range		0.4		2.2	GHz
Noise Figure	0.4		1.0		dB
	0.9		0.8		
	1.2		0.9		
	1.6		1.1		
	2.2		1.2		
Gain	0.4	—	32.3	—	dB
	0.9	—	31.8	—	
	1.2	28.1	31.6	34.5	
	1.6	—	30.0	—	
	2.2	—	25.4	—	
Input Return Loss	0.4		15.3		dB
	0.9		9.1		
	1.2		9.7		
	1.6		12.2		
	2.2		16.5		
Output Return Loss	0.4		21.3		dB
	0.9		17.1		
	1.2		14.7		
	1.6		14.2		
	2.2		21.5		
Output IP3	0.4		35.7		dBm
	0.9		36.1		
	1.2		36.5		
	1.6		37.2		
	2.2		37.3		
Output Power @ 1 dB Compression ⁽²⁾	0.4	—	22.1	—	dBm
	0.9	—	22.8	—	
	1.2	20.0	23.3	—	
	1.6	—	23.7	—	
	2.2	—	23.4	—	
DC Volts (Vd)		4.8	5.0	5.2	V
DC Current (Id)			158	186	mA
DC Current Variation Vs. Temperature ⁽³⁾			-0.156		mA/°C
DC Current Variation Vs. Voltage			0.027		mA/mV
Thermal Resistance ⁽⁵⁾			48		°C/W

⁽¹⁾ Measured on Mini-Circuits Characterization test board TB-758+. See Characterization Test Circuit (Fig. 1)

⁽²⁾ Current increases at P1dB

⁽³⁾ (Current at 85°C - Current at -45°C)/130

Absolute Maximum Ratings⁽⁴⁾

Parameter	Ratings
Operating Temperature ⁽⁵⁾	-55°C to 105°C
Storage Temperature	-65°C to 125°C
Channel Temperature	150°C
DC Voltage	6V
Power Dissipation	1.35 W
Input Power	25 dBm

⁽⁴⁾ Permanent damage may occur if any of these limits are exceeded.

These maximum ratings are not intended for continuous normal operation.

⁽⁵⁾ Defined with reference to ground pad temperature.

DC Current Histogram

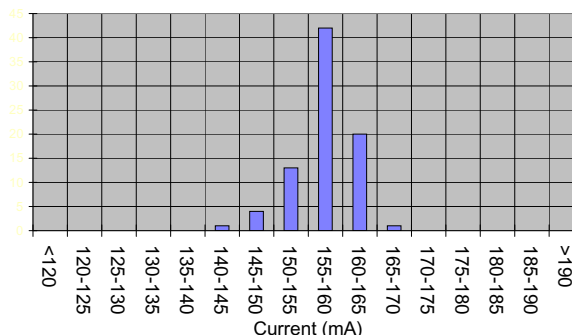

Characterization Test Circuit

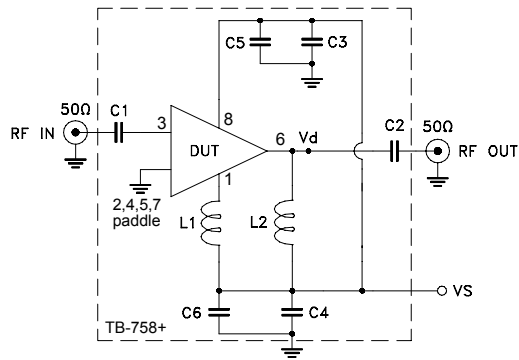
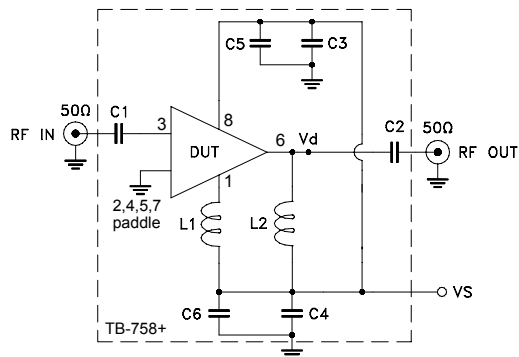

Fig 1. Block Diagram of Test Circuit used for characterization. (DUT soldered on Mini-Circuits Characterization Test Board TB-758+) Gain, Output power at 1dB compression (P1dB), Output IP3 (OIP3), Noise Figure are measured using Agilent's N5242A PNA-X microwave network analyzer.

Conditions:

1. Gain: Pin=-25 dBm
2. Output IP3 (OIP3): Two tones, spaced 1 MHz apart, 0 dBm/tone at output.
3. Vs adjusted for 5V at device (Vd), compensating loss of bias tee.

Recommended Application Circuit



Component	Description
DUT	PMA-545G1+
C1, C2, C5, C6	100 pF
C3, C4	1μF
L1	36 nH
L2	47 nH

Fig 2. Recommended Application Circuit

Suggested PCB Layout (PL-405)

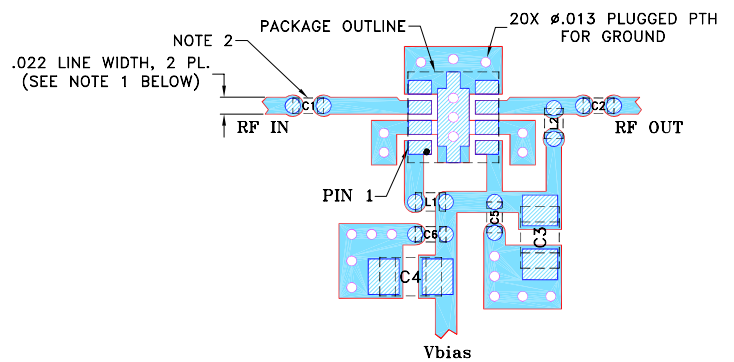

- NOTES: 1. TRACE WIDTH IS SHOWN FOR ROGERS R04350B WITH DIELECTRIC THICKNESS .010" ± .001"; COPPER: 1/2 OZ. EACH SIDE. FOR OTHER MATERIALS TRACE WIDTH MAY NEED TO BE MODIFIED.
2. 0402 AND 0805 SIZE CHIP FOOT PRINTS SHOWN FOR REFERENCE. FOR COMPONENT VALUE REFER TO TB-758+.
3. BOTTOM SIDE OF THE PCB IS CONTINUOUS GROUND PLANE.
- DENOTES PCB COPPER LAYOUT WITH SMOBC (SOLDER MASK OVER BARE COPPER)
 - DENOTES COPPER LAND PATTERN FREE OF SOLDER MASK

Product Marking

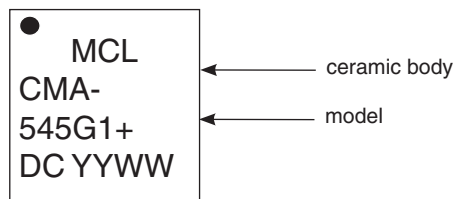

Additional Detailed Technical Information	
<i>additional information is available on our dash board. To access this information click here</i>	
Performance Data	Data Table
	Swept Graphs
	S-Parameter (S2P Files) Data Set (.zip file)
Case Style	DL1721 <i>Ceramic package, exposed paddle, Terminla finish: NiPdAu</i>
Tape & Reel Standard quantities available on reel	F66-1 <i>7" reels with 20, 50, 100, 200, 500 or 1K, 2K devices.</i>
Suggested Layout for PCB Design	PL-405
Evaluation Board	TB-758+
Environmental Ratings	ENV-68

ESD Rating

Human Body Model (HBM): Class 1B (500 to <1000V) in accordance with ANSI/ESD STM 5.1 - 2001

Machine Model (MM): Class M1 (pass 35V) in accordance with ANSI/ESD STM5.2-1999

MSL Rating

Moisture Sensitivity: MSL1 (these parts are hermetic, air cavity and therefore, MSL ratings do not strictly apply. For handling purpose, use MSL1)

Qualification Testing

	Test Description	Test Method/Process	Results
1	Hermeticity (fine and gross leak)	MIL-STD-202 Method 112, Cond. C & D	Pass
2	Acceleration, 30Kg, Y1 Direction	MIL-STD-883 Method 2001 Cond. E	Pass
3	Vibration , 10-2000Hz sine, 20g, 3 axis	MIL-STD-202 Method 204, Cond. D	Pass
4	Mechanical shock	MIL-STD-202 Method 213, Cond . A	Pass
5	PIND 20G's @130 Hz	MIL-STD-750 Method 2052.2	Pass
6	Temp Cycle -55C/+125C, 1000 Cycles	MIL-STD-202 Method 107	Pass
7	Autoclave, 121C, RH 100%, 15 Psig, 96 hrs	JESD22-A102C	Pass
8	HTOL, 1000hrs, 105C at rated Voltage condition	MIL-STD-202 Method 108, Cond . D	Pass
9	Bend Test	JESD22-B113	Pass
10	Resistance to soldering heat, 3x reflow, 260C peak	JESD22-B102	Pass
11	Drop Test	JESD22-B111	Pass
12	Adhesion Strength	Push Test>10 lb	Pass

Additional Notes

- A. Performance and quality attributes and conditions not expressly stated in this specification document are intended to be excluded and do not form a part of this specification document.
- B. Electrical specifications and performance data contained in this specification document are based on Mini-Circuit's applicable established test performance criteria and measurement instructions.
- C. The parts covered by this specification document are subject to Mini-Circuits standard limited warranty and terms and conditions (collectively, "Standard Terms"); Purchasers of this part are entitled to the rights and benefits contained therein. For a full statement of the Standard Terms and the exclusive rights and remedies thereunder, please visit Mini-Circuits' website at www.minicircuits.com/MCLStore/terms.jsp

